

National Skills Competition  worldskills
INTERNATIONAL VOCATIONAL TRAINING ORGANIZATION

Industrial Maintenance

Test Project



Skills Area: Welding & Fabrication

National Skills Competition

WorldSkills Jamaica Competition April 24 to 25, 2008

General Instructions

1. Each competitor will be required to carry out the test project as specified and will be available on the website three months before the competition.
www.worldskillsjamaica.org
2. Each competitor will be required to carry out the test project as specified on the schedule to be handed out two days before the competition.
3. The time will be specified according to the test project.
4. 20% change will be made to the test project on the day of the competition where a new test project will be issued to the competitor.
5. All materials, ingredients, large equipment and specialized hand tools will be provided.
- 6. Please note that all competitors should provide their own small tools and utensils.**
7. Competitors are expected to identify all equipment/ materials/ingredients needed and submit list to the competitions committee no later than March 7, 2008.
8. Debriefings will also be conducted for all competitors on April 22, 2008.
9. All competitors will get an opportunity to arrange work areas the day before the competition. Where applicable competitors for the second day will arrange their work areas on the evening of day one. Competitors who fall in the second shift will get an opportunity to do their preparation at offsite locations (to be decided) where necessary.
- 10. Competitors and coaches are expected to find their way to the competition village on April 22, 2008 and to depart back home on April 26, 2008**
- 11. Transportation will be provided at designated times for all competitors and coaches to and from the competition venue.**
- 12. All coaches will play the role of experts (judges) for the competition**
- 13. Accommodation and meals will be provided for all competitors**

14. Accommodation will be provided for coaches only.

15. All other persons that support the competitors will need to make their own accommodation arrangements.

16. Lunch and light refreshment only will be provided for coaches, (experts), workshop supervisors, national trade managers and volunteers.

17. All competitors should be present for the opening ceremony along with their coaches.

18. Rehearsal for the opening ceremony will be held on the evening of April 22, 2008 in the Indoor Sports Centre.

19. Competitors are not allowed out of the competition village unless permission is granted by the dorm master.

20. All competitors are required to register at the competition village to qualify for entry into the competition.

21. Special permission must be granted if competitors need to reside off campus.

CONTENTS

SECTION 1: General Information

SECTION 2: Introduction

SECTION 3: Competitor's Instructions

SECTION 4: Material & Equipment Listing

SECTION 5: Drawings

WELDING SKILLS TEST PROJECT

Instructions: Competitors are required to complete the following three tasks.

Tasks 1 – Tig weld

- A) Obtain two (2) pieces of aluminum of dimensions 2" X 6" X 1/8"
- B) Set welding parameters
- C) Assemble as a T – joint using GTMAW process.
(Weld on one side only)

Task 2 – Mig weld

- A) Obtain two pieces of mild steel plate of dimensions 2"X 6"X 1/4" and chamfer edges appropriately

WorldSkills competition
April 2008

- B) Set welding parameters
- C) Set work in a vertical position
- D) Assemble as a butt – joint
(Weld on one side only)

Task 3 – MMAW

- A) Obtain two pieces of mild steel plate of dimensions 2”X 6”X ¼” and chamfer edges appropriately
- B) Set welding parameters
- C) Set work in a vertical up position
- D) Assemble as a butt - joint

(Weld on one side only, full root penetration is required)

All competitors will be allocated a competitor number and work stations by the expert/judge using a ballot other wise.

Equipment

Adequate materials and equipment will be available to each competitor.

Please check all materials and tools when they are supplied to you to ensure they are correct and not damaged.

Marks will be deducted if more materials is required unless it was faulty when supplied.

Replacement parts for any equipment must be requested through an expert/judge.

Personal Safety Rules

During the competition, all candidates MUST follow the safety rules listed below:

WorldSkills competition
April 2008

Any candidate, who in the opinion of the experts/judges is not wearing the correct safety, attire or is engaging in any unsafe practice, will be stopped and not allowed to continue until the issue is resolved. The candidate will also lose marks.

SHOES:

- Fully enclosed work shoes or boots must be worn at all times.

CLOTHING

- Legs must be covered at all times, by either long work trousers or overalls.
- Upper body must be covered at all times.
- Arms must be covered with long sleeves, when welding
- A leather apron must be worn at all times.

SAFETY GLASSES/FACE SHIELD

- Must be worn when necessary to protect your eyes.
- Must be worn when brazing, soldering, welding and grinding.
- Must be worn when performing overhead welding.

GLOVES

- Must be worn when welding and grinding.

HELMET

- Must be worn when performing overhead welding

ELECTRICAL

- Candidates must not switch on (apply power) to any electrical equipment until they receive permission from an expert/judge, except for hand power tools

Any candidate, who in the opinion of the experts, is not wearing the correct safety attire or is engaging in any unsafe practice, will be stopped and NOT

WorldSkills competition
April 2008

allowed continue until the issue is resolved. The candidate will also lose marks.

EQUIPMENT TO BE SUPPLIED BY THE CANDIDATE

- | | |
|------------------------------|---------------------------|
| * Personal Protective Gears | * Tape Measure/Steel rule |
| * Stainless Steel Wire Brush | * Chipping Hammer |
| * Wire Brush with Scraper | * Hacksaw |
| * Flint | * Flat File |
| Soap stick | Half round file |

EQUIPMENT TO BE PROVIDED BY THE ORGANIZERS

The equipment and tools is be supplied by the organizers.

CANDIDATE WORK AREA

Each candidate work area should contain the following equipment.

EQUIPMENT

- | | |
|---|---------------------------------|
| * Miller Matic Pulse MIG machine | * Syncrowave 250DX TIG runner |
| * Dialarc 250ac/dc welding machine (SMAW) | * Shelded Metal Welding Machine |
| * Bench Vice (600 x 1200 x 800 H) | * Grinder |
| * 7" Dewalt handle grinder | * Profile Cutter (Plate) |
| * Oxyacetylene Cutting Equipment | * Electrode Warmer |

MATERIALS

* Mild Steel Plate @ 4" X 8" X ½"

* E6010 Electrode 3/32

* E7018 Electrode 5/32 (optional 1/8")

* Cutting Disc (4 or 4½")

* Grinding Disc (4 or 4½")

Test Project - Welding

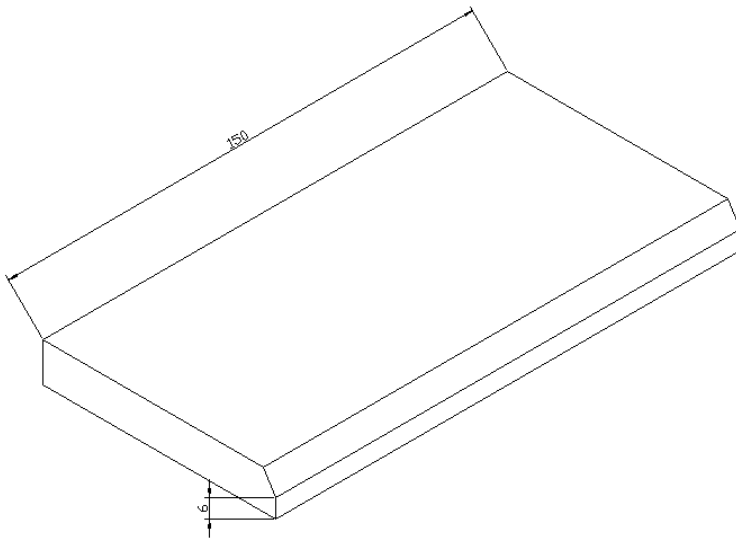
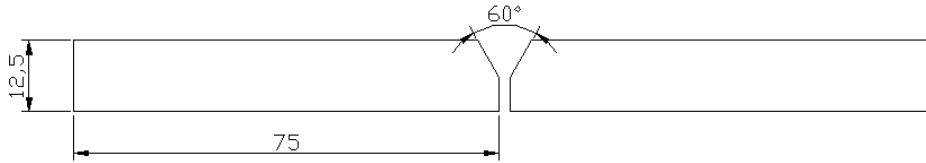

Length of plate 6" or 150mm
Width of plate 3" or 75mm

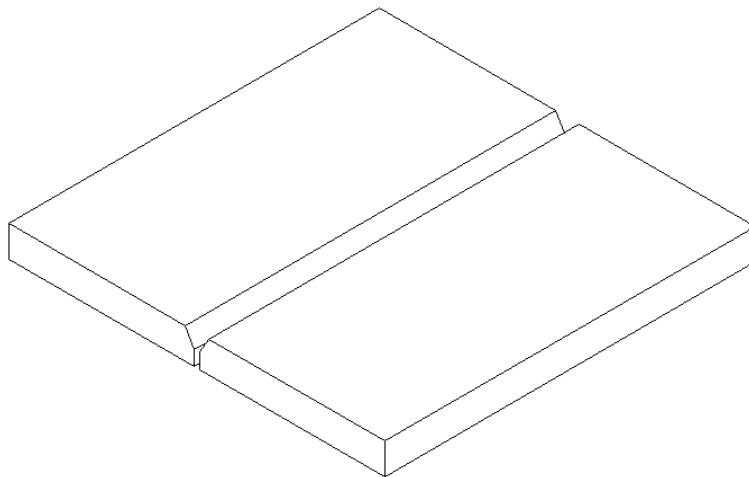

WorldSkills competition
 April 2008

**OBJECTIVE MARKING
 FORM 5**

SKILLS JAMAICA 2008

Skill Area Instrument Maintenance

Competitor # _____ Competitor Name _____

Criterion #	Aspect of Criterion Description	Mark allotted for objective marking	Total Mark received for objective Marking	Total Mark received for Subjective Marking	Overall Mark Awarded
1	Visual Assessment of weld seams	20			
2	Non-Destructive tests (dye penetrant)	15			
3	Work is assembled according	20			
4	Joints are properly welded	10			
5	Correctly following welding instructions	10			
6	Accuracy (tolerance = $\pm 1/16''$)	15			
7	Work is completed within the allotted time	5			
8	Smooth welded joints	5			

Total Mark awarded _____ **Type of Medal** _____

Signatures

Judge 1

Judge 2

Judge 3

Judge 4

Chief Judge
Date

CIS scoring

**All competitors will be scored using the Computer Information System (CIS)
 – (400 to 600 possible points)**

500 – Medallion of excellence

Top three scores will receive gold, then silver, then bronze

SUBJECTIVE MARKING

FORM 5A

SKILLS JAMAICA 2008

Skill Area: Instrument Making

Competitor # _____ **Competitor Name** _____

Criterion #	Aspect of Criterion - Description	Judge score (Out of 10)					Mark Awarded
		1	2	3	4	5	
1	Preparation						
2	Selection of Tools						
3	Use of Tools						
4	Job Knowledge						
5	Material Usage						
6	House Keeping						
7	Safety						
8	Presentation						
9							
10							

Formula for Subjective Marking total score:
Exclude the highest and the lowest score and find the average of the remaining three.

Total Mark awarded _____

Signatures

Judge 1	Judge 2	Judge 3	Judge 4

Chief Judge
Date

Score for subjective marking should be entered on form 5 for total score.