



*National Skill Competition*



# *Building and Construction*

## *Test Project*



*Skill Area: Joinery and Cabinet Making*

National Skills Competition Date: March 30-31,  
2005

## Skills Jamaica Competition March 30-31, 2005

### General Instructions

- (1) Each competitor will be required to carry out the test project as specified on the schedule to be handed out two days before the competition.
- (2) The time will be specified according to the test project.
- (3) Minor adjustments may be made to the test project on the day of the competition where a new test project will be issued to the competitor.
- (4) Competitors are expected to identify all equipment/ materials/ingredients needed and submit list to the competitions committee no later than January 28, 2004.
- (5) **Please note that all competitors should provide their own small tools and utensils.**
- (6) Competitors will be given a schedule two days before the competition. Debriefings will also be conducted for all competitors on March 28, 2004.
- (7) All competitors will get an opportunity to arrange work areas the day before the competition. Where applicable competitors for the second day will arrange their work areas on the evening of day one. Competitors who fall in the second shift will get an opportunity to do their preparation at offsite locations (to be decided) where necessary.
- (8) All competitors should be present for the opening ceremony along with their instructors/coaches.
- (9) Rehearsal for the opening ceremony will be held on the evening of March 28, 2005 (National Indoor Sport Center at 6 pm).

**All competitors will be allocated a competitor number and work stations by the expert/judge.**

### ***Equipment***

Adequate material and equipment will be available to each competitor.

Please check all materials and tools when they are supplied to you to ensure they are correct and not damaged.

Makes will be deducted if more materials required unless it was faulty when supplied.

Replacement parts for any equipment must be requested through an expert/judge.

### ***Personal Safety Rules***

During the competition, all candidates MUST follow the safety rules listed below:

*Any candidate, who in the opinion of the experts/judges, is not wearing the correct safety attire or is engaging in any unsafe practice, will be stopped and not allowed to continue until the issue is resolved. The candidate will also lose marks.*

#### **General:**

Never leave a running machine unattended.

Keep hands away from moving parts of the machines and away from work and tools when the machines are running.

Clean the area and machine after each usage

#### **Shoes:**

Fully enclosed work shoes or boots must be worn at all times.

#### **Clothing:**

Legs must be covered at all times, by either long work trousers or overalls.

Upper body must be covered at all times.

Do not wear long sleeves, loose clothing, tie, watches, ring or an item that could be caught in the machine. If your hair is long, wear it up or in a hair net.

**Clear Safety Glasses:**

Must be worn when necessary to protect your eyes.

**Gloves:**

Must be worn when necessary to protect your hands.

**Instructions:**

Candidates are required to construct and apply natural lacquer finishes to computer desk along with other specification given.

## **List of Material for Joinery & Cabinet Making**

1. ½ Lengths of 2" x 2" x 10" rough pitch pine
2. ½ Lengths of 1" x 4" x 12" rough pitch pine
3. ½ Lengths of 1" x 10" x 12" rough pitch pine
4. ½ Lengths of 1" x 3" x 12" rough pitch pine
5. ½ Lengths of 1" x 12" x 16" rough pitch pine
6. 1 Qrt. of Ponal glue
7. 1 Doz 1½" dry wall screw
8. 1 Sanding Belts (1.60 grade, 1.80 grade)
9. 2 Sheets each of assorted Sand paper (water) [120, 180, 240, 320]
10. 2 Qrt. of Lacquer Thinner
11. 1 Qrt. Sealer
12. 1Pint of Lacquer

## **List of Hand and Power Tools**

- Power Tools
- Circular Saw
- Jointer
- Try Saw
- Radial Arm Saw
- Belt Sander
- Vibrator
- Hand Drill
- Mortiser
- Compound Saw

## Competitors to Provide Hand Tools

- Jack plane
- Tenon Saw
- Mallet
- Hammer
- Chisel 1", 2/8, 1/4
- Oil stone Try Square
- Scraper
- Mortise Gauge
- Nail Set
- Pencil
- Measuring Tape

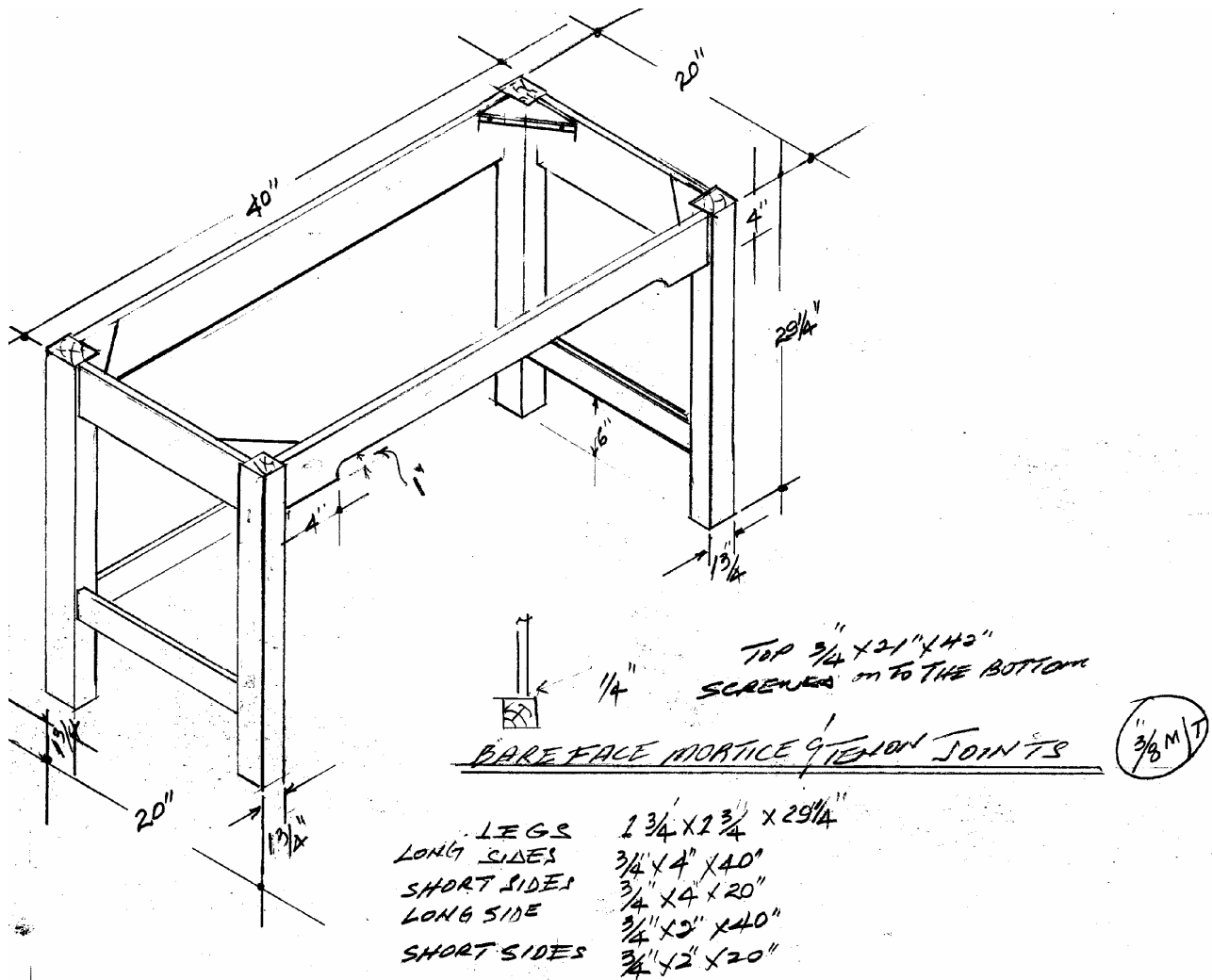

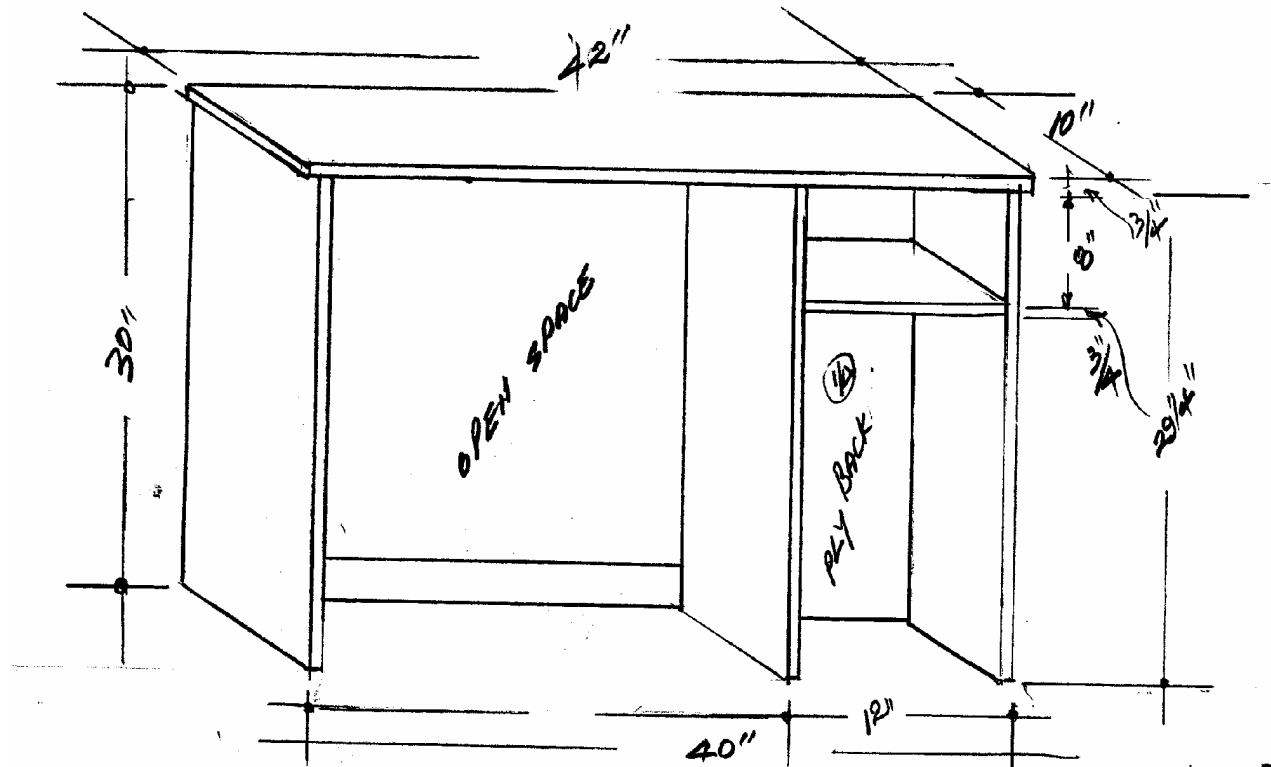

SIDES -  $\frac{3}{4}$ "  $\times$  10"  $\times$  29  $\frac{1}{4}$ " FINISH WITHOUT LIP OR TOP  
 SHELF  $\frac{3}{4}$ "  $\times$  10"  $\times$  12"  
 BACK RAILS  $\frac{3}{4}$ "  $\times$  3"  $\times$  40"  
 TOP  $\frac{3}{4}$ "  $\times$  21"  $\times$  42"